



ALPHA

Air Cooling Recycling Extruder

The **ALPHA** recycling extruder uses Plasmac's unique Short Screw Technology (SST), which is based around a dual diameter 8:1 L/D ratio screw.

PRINCIPLE OF OPERATION

The waste material is directly fed on to the screw meaning no prior size reduction is required, due to this little or no dust is produced which means a higher quality pellet is produced with the lowest levels of gels possible. The S.S.T. ensures low shear, runs at low melt temperatures and therefore guarantees an absolute minimum of material degradation.



MAIN FEATURES

Minimal power consumption & the highest output / kW of installed power in the market

Giving you lower running cost and therefore the quickest return on your investment.

Low shear, minimum process dwell time and the absolute minimum of material degradation

Means you can recycle all of your scrap material into high quality pellets, reducing your material costs and improving your profitability.

Direct extrusion design, no prior size reduction required

Requires no other costly equipment, reduces maintenance and increases your productivity, therefore improving your profitability.

Smallest footprint recycling machine available on the market

Minimal floor space is required.

TRIM BASKET

For feeding inline trims into the recycling extruder.

FLAKE FEEDER

Used to feed flakes or chips into the extruder.

REELFEED

Used to feed off-spec or scrap reels into the extruder, can be used simultaneously with the trim basket.

SUPATRIM

Used to convey tacky or extensible trims to the extruder, can be used simultaneously with the trim basket.

SCREEN CHANGERS

Manual or automatic systems available, used when running offline products i.e. reels, flake etc.

VACUUM DEGASSING STATION

Single or double venting systems available to allow you to run printed or hydroscopic materials.

DTEC

A pellet detection system to advise if there are issues in the pelletiser.

TECHNICAL DATA

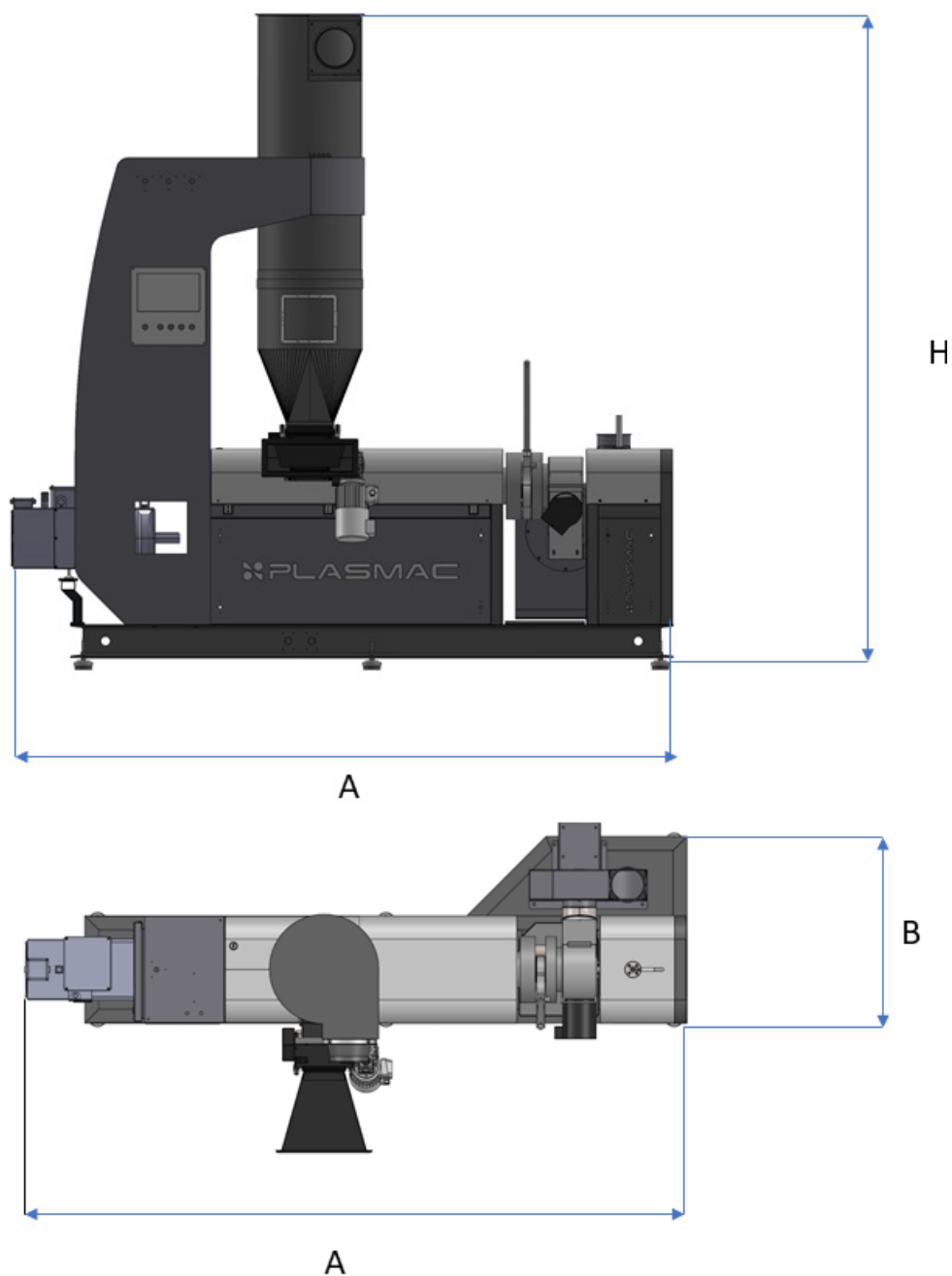

MODEL	Output Kg/h*	Motor kW	Floor Space m ²	A (mm)	B(mm)	H (mm)	Weight ** Kg
35 AC	25	7.5	2.11	2300	920	2800	550
40 AC	35	11	2.20	2400			580
45 AC	45	11		650			
50 AC	55	15	2.48	2700			850
60 AC	75	15		1100			
60E AC	90	18.5	2.62	2850	950	3000	1100
70 AC	130	30	2.94	300		1300	
80 AC	180	37	5.46	4200		1300	1450

* Depends on the type and the format of the material

** Depends on the installed accessories