



# EPSILON

## The most efficient recycling extruder available in the market

The **EPSILON** recycling inline shredder extruder system uses Plasmac's unique Short Screw Technology (SST), which is based around a dual diameter 8:1 L/D ratio screw.

### PRINCIPLE OF OPERATION

The waste material is fed via trim basket, rollfeed or elevator, in to the inline shredder, the size reduced material is then fed directly in to the feed throat of the extruder. No water cooling or compressed air is needed and the slow rotating shredder rotor ensures dust generation is kept to a minimum which means a higher quality pellet is produced with the lowest levels of gels possible. The S.S.T. ensures low shear, runs at low melt temperatures and therefore guarantees an absolute minimum of material degradation giving you the highest quality recycled pellet.

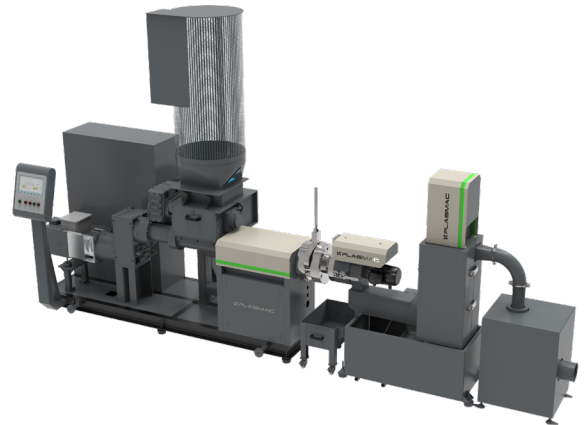

### MAIN FEATURES

#### **Minimal power consumption & the highest output / kW of installed power in the market**

Giving you lower running cost and therefore the quickest return your on investment with paybacks in as little as six months

#### **Low shear, minimum process dwell time and the absolute minimum of material degradation**

Means you can recycle all of your scrap material into high quality pellets, reducing your material costs and improving your profitability

#### **Slow rotating inline shredder technology and unique feed hopper design**

Requires no cooling water of the rotor, reduces maintenance and costs, therefore improving your profitability

#### **Smallest footprint recycling machine available on the market**

Minimal floor space is required freeing up valuable floor space for other applications

#### **AIR or WATER COOLED PELLETISER**

Air or water pelletisers, the materials or output being run will determine the type of pelletiser required

#### **TRIM BASKET**

For feeding inline trims into the recycling extruder

#### **REELFEED**

Used to feed off-specification reels or scrap reels into the extruder, can be used simultaneously with the trim basket

#### **SUPATRIM**

Used to convey loose, slabbed, pieces and small lumps in to the shredder

#### **SCREEN CHANGERS**

Manual or automatic systems available, used when running offline products such as reels, flake etc.

#### **VACUUM DEGASSING STATION**

Single or double venting systems available to allow you to run printed materials or materials with moisture in them

#### **DTEC**

A pellet detection system to advise the operator if there are issues in the pelletiser

TECHNICAL DATA

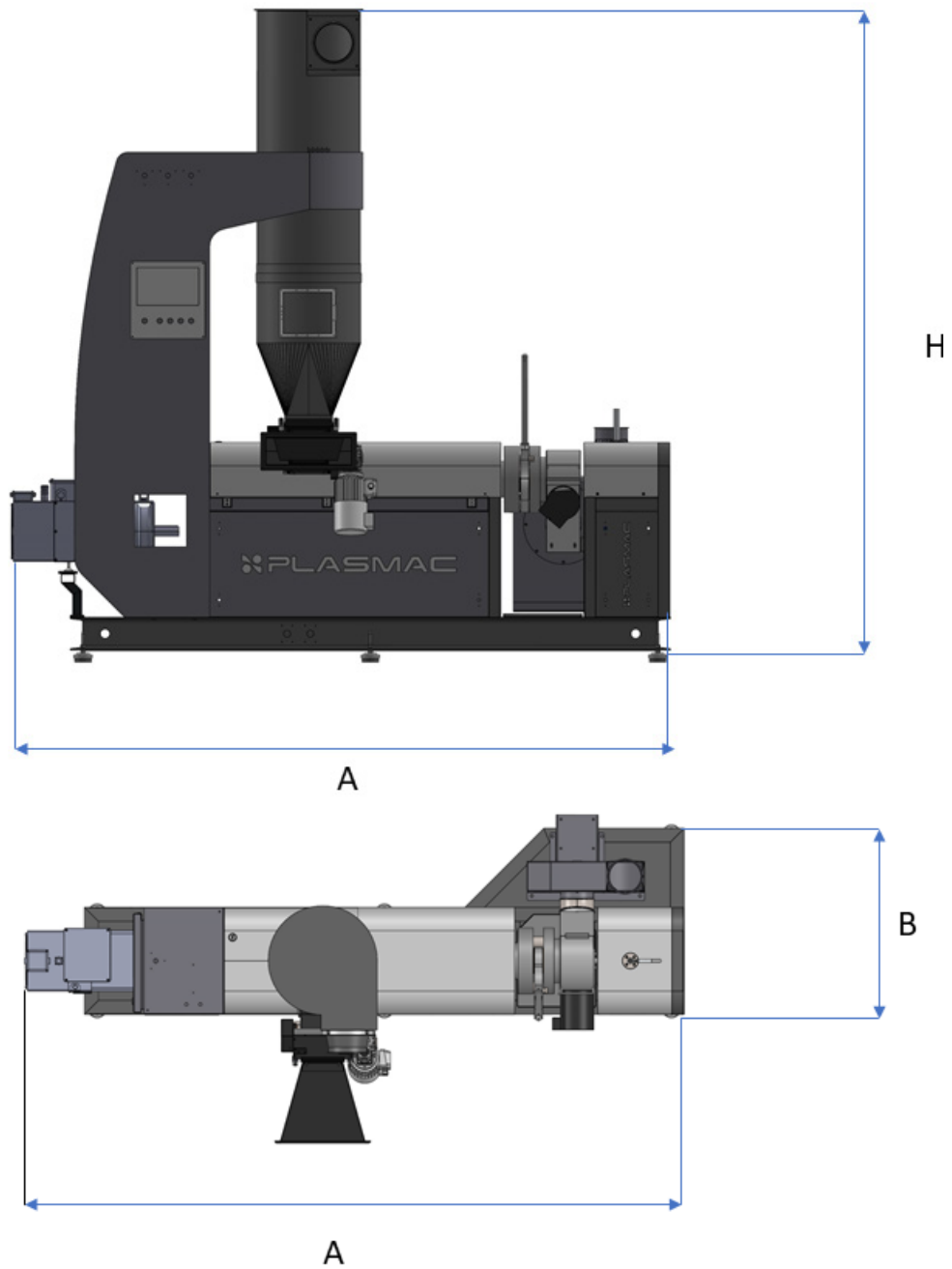

MODEL	Output Kg/h*	Motor kW	Floor Space m <sup>2</sup>	A (mm)	B(mm)	H (mm)	Weight ** Kg
45	45	11	6.214	4780	1300	2200	1800
60	75	15	6.37	4900	1300	2200	2010
60 ECO	95	18.5	6.526	5020	1300	2200	2150
70	130	30	6.63	5100	1300	2200	2300
80	160	37	7.54	5800	1300	2200	2600

All dimensions are subject to change based on the configuration of the machine.

\* Depends on the type and the format of the material

\*\* Depends on the installed accessories