



# PWB

## Conveyor belt for pre-weighed additives "PWB"

The conveyor belt PWB is the automatic solution to feed in turbo mixer pre weighed bags.

### PRINCIPLE OF OPERATION

The pre-weighed bags containing small quantity of additives necessary for the blend are housed on the belt which can contained up to 20 bags. Every mixing cycle one bag is discharged through a discharge hopper in the mixer together with the main components.



### MAIN FEATURES

#### WIDE RANGE OF MODELS

The wide range of different size can satisfy different production requirements. Two standard models for 10 or 20 bags, and possibility to realize customized solution for more bags and with inclinations from the ground up to 30°.

#### INSTALLATIONS

PWB is always supplied prewired with junction boxes to permit an easy and fast installation.

The system is equipped with sensors able to check the presence, the advancement and the discharge of the bag. The belt is realized with separator which allows the bags to be housed in dedicated spaces to advance at every cycle.

#### CONTROL SYSTEM & INDUSTRY 4.0

The control system can be integrated with the main production supervisory, satisfying the OPC/UA protocol, which make each machine modular and ready for industry 4.0.

TECHNICAL DATA

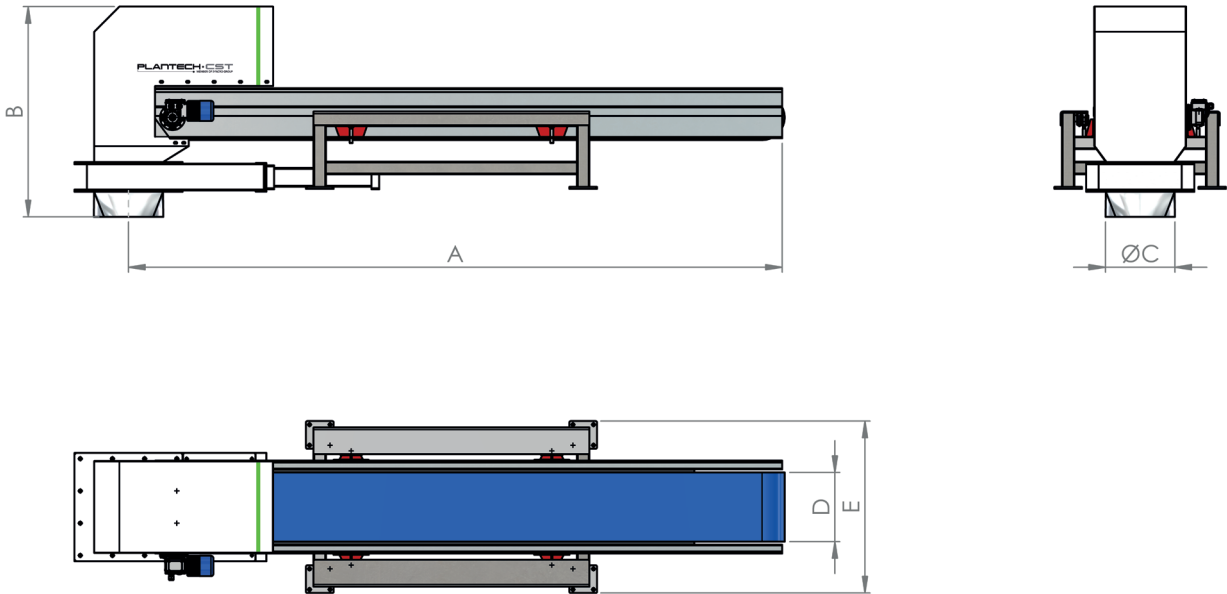

Code	N° of Bags	A [mm]	B [mm]	ØC [mm]	D [mm]	E [mm]
PWB-10	10	2600	840	250	300	685
PWB-20	20	4900	840	250	300	685