

GRANULATORI A FIANCO MACCHINA SIDE-MACHINE GRANULATORS GRS

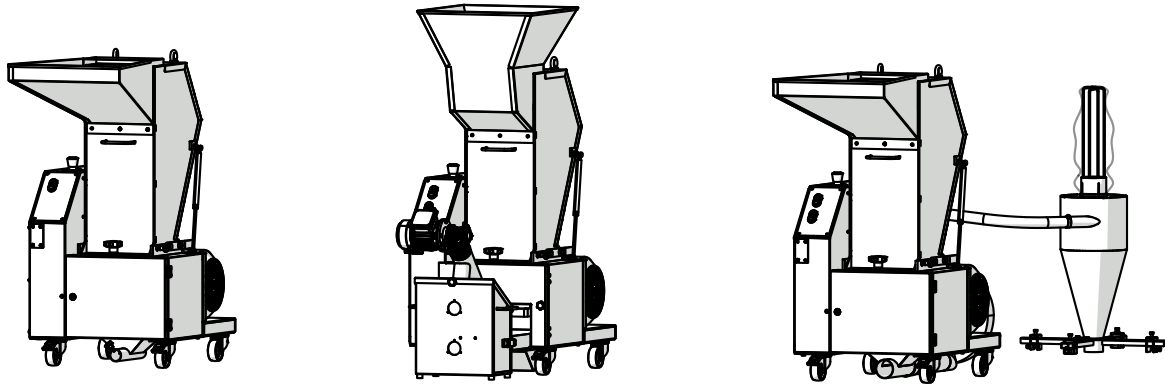

Indicato per macinazione materozze / Indicated for sprues grinding

Applicazioni: isole di stampaggio - bordo macchina / Applications: injection molding area - side machine

Caratteristiche tecniche / Technical specifications

GRS	152	202	302	402
Bocca di alimentazione / Feed opening (mm)	140x180	200x180	280x180	397x180
Potenza motore di dosaggio / Motor power (kW)	1,5	2,2	3	4
Giri rotore / Rotor speed (RPM)	230			
Insonorizzazione / Soundproof	x	x	x	x
Tensione / Tension (V-Hz)	400-50			

Allestimenti - Opzioni / Technical features - Options (1)

	GRS
Tipi di imbuto: robot, nastro, ribassato / Funnel types: robot, belt, lowered	x
Lame in acciaio temprato / Blades in hardened steel	x
Estrazione materiale con box di raccolta / Material extraction with collection box	x
Estrazione materiale con coclea / Material extraction with screw	o
Estrazione materiale con ventilatore e ciclone polveri / Material extraction with fan and dust cyclone	o
Versione rialzata / Raised version	o
Pacchetto lame modulari / Modularity of blades pack	x
Lame di taglio affilabili / Sharpenable cutting blades	x

GRANULATORI A FIANCO MACCHINA SIDE-MACHINE GRANULATORS GRS

Configurazioni / Configurations

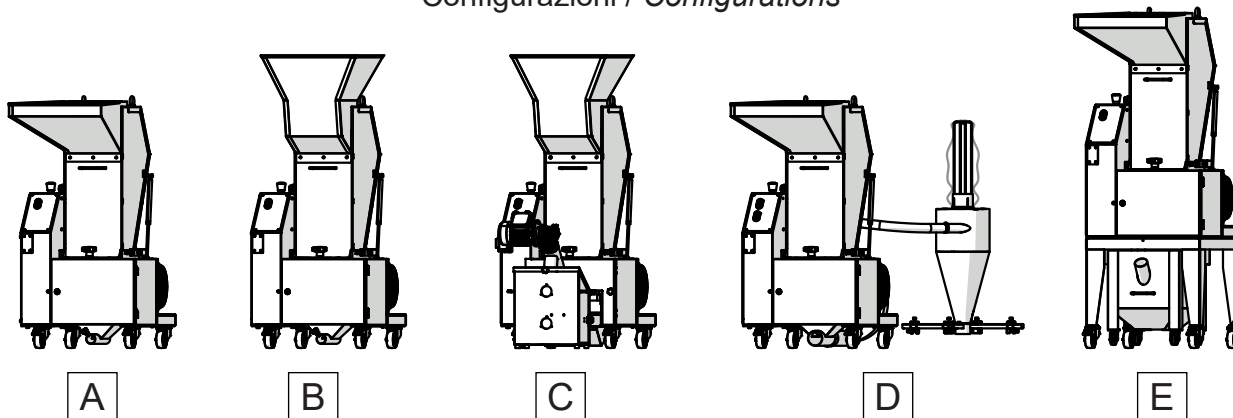

A	IMBUTO ROBOT / ROBOT FUNNEL
B	IMBUTO NASTRO / BELT FUNNEL
C	ESTRAZIONE CON COCLEA / EXTRACTION WITH SCREW
D	ESTRAZIONE CON VENTILATORE E CICLONE / EXTRACTION WITH SCREW AND CYCLONE
E	VERSIONE RIALZATA / RAISED VERSION

Dimensioni e pesi / Dimensions and weights (2)

GRS	152				202			
	Nastro / Belt	Robot	Ventilatore / fan	Coclea / Scew	Nastro / Belt	Robot	Ventilatore / fan	Coclea / Scew
L1 (mm)	430				490			
L2 (mm)	895	805	(+360)	(+350)	920	830	(+360)	(+350)
H (mm)	1160	1340	=	=	1160	1340	=	=
Kg	200	200	210	230	215	215	225	245

GRS	302				402			
	Nastro / Belt	Robot	Ventilatore / fan	Coclea / Scew	Nastro / Belt	Robot	Ventilatore / fan	Coclea / Scew
L1 (mm)	560				690			
L2 (mm)	920	830	(+360)	(+350)	920	830	(+360)	(+350)
H (mm)	1160	1340	=	=	1160	1340	=	=
Kg	230	230	240	260	245	245	255	275

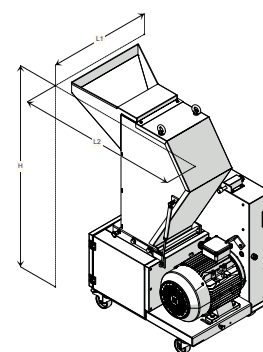

(2) Dimensioni e pesi indicativi / Indicative dimensions and weights

SB DRY SRL

Via L. Pierobon, 8
35010 Limena (PD)
Italy

Tel. +39 049 88.43.047
Fax + 39 049.88.43.081

sales@sbplastics.it
www.sbplastics.it

CF & PIVA 04522430281
REA PD - 396666

GRS_DS_00_IT-EN_Rev0

