



easybatch

The Traditional Weighted Batch Blender

EASYBATCH is a traditional weighted batch blender, designed to dose and blend multiple components in sequence for all processes where constant gravimetric feeding and an homogeneous mix is required.

PRINCIPLE OF OPERATION

Each ingredient is metered in sequence by slide gate valves in to the weighing hopper mounted on two load cells. Once the pre-set batch weight has been reached, the load cell sends a signal and the batch is released into the weighing & mixing chamber which combines the batch and the Loss In Weight technology.



MAIN FEATURES

GRAVIMETRIC EXTRUSION THROUGHPUT

The mixer is mounted on two load cells and measures the LIW, controlling the extrusion throughput with continuous accuracy.

WIDE RANGE OF SETTING

Due to the different dosing ratios each component can be switched in future from low to high dosing rates.

CONVEYING SYSTEM

EASYBATCH can be supplied along with an integrated centralised conveying system controlled by the same PLC as the blender.

CLEANING

Easy cleaning thanks to the drain spout installed on each hopper plus a compressed air gun is also included.

HMI

The blender can be equipped with a HMI touch screen (5.7" - 7" - 10") onboard or supplied in a separate remoted box.

PLC INDUSTRY 4.0 & IoT

EASYBATCH has a PLC with protocol UPC/UA embedded. This solution makes each blender modular and ready for Industry 4.0.

MIXER MOTOR SYNCRO

EASYBATCH uses a three phase motor for its mixer along with a dry gearbox avoiding any possible motor overheating and oil leaking.

MIXER SHAPE

Spherical shaped mixer avoids any residual material hang-up.

EASY ACCESS FOR MAINTENANCE

The inspection doors, designed to facilitate access to the machine, speed up cleaning and maintenance operations.

MODULARITY



TECHNICAL DATA

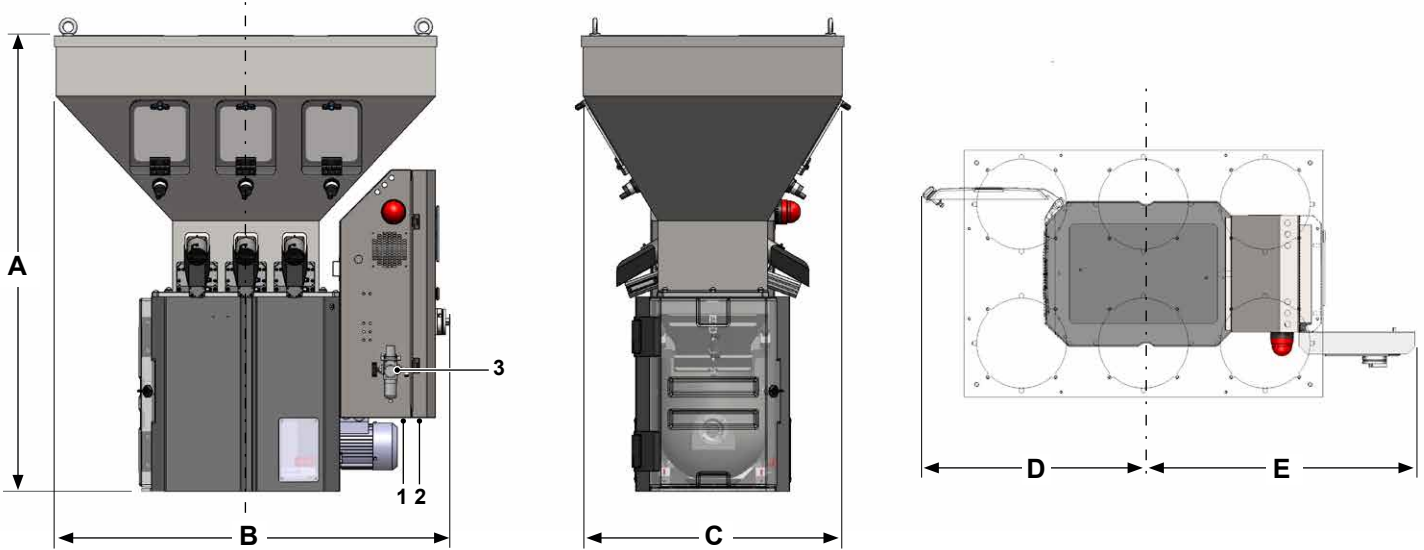

Model	S2	S3	S4	S5	S6	SP2	SP3	SP4	SP5	SP6	M2	M3	M4	M5	M6	L2	L3	L4	L5	L6
Nominal inlath throughput (kg/h)	295	275	255	230	210	400	375	350	325	300	930	865	815	740	700	1390	1300	1220	1120	1045
Max Batch Weight (kg)	2,5					4					7					12				
Gross Volum single compartment (L)	38	26		25,6		38	26		26,5		68	80		96		85	128		125	
Range of flow rates* max (kg/h) (calculated according to standard recipes)**	310 450	232 395	330 365	170 325	160 295	415 640	440 585	500 550	350 500	330 470	995 1275	790 1125	910 1020	600 915	550 835	1545 1760	1335 1600	1400 1485	1105 1360	1005 1265
Installed Power(kW)	0,9															1,13				
Consumption Power (kW)	0,6															0,8				
Consumption Compressed Air (NI/h)	85	125	165	205	245	85	125	165	205	245	100	150	200	250	300	100	150	200	250	300
Suitable MAX valve Ø (mm)	44										60									
Suitable hopper loader model	F270										F270 - F370					F270 - F370 - F470				
Weight (kg)	106	118	120	148	150	126	138	140	168	170	170	188	190	218	220	200	218	220	248	250
A (mm)	1145					1295					1470					1745				
B (mm)	755	815		1145		755	815		1145		815	895		1268		815	895		1268	
C (mm)	660										870									
D (mm)	610					670					730									
E (mm)	720										770									

* Flow rate values are calculated considering the apparent density of the granule = 0,55 kg/dm3. They vary according to the grain size of the material.

** 2 ingredients (50-100%, 1-10%); 3 ingredients (50-100%, 2-20%, 1-10%); 4 ingredients (50-100%, 50-100%, 2-20%, 1-10%); 5 ingredients (50-100%, 50-100%, 2-20%, 1-10%, 1-10%); 6 ingredients (50-100%, 50-100%, 2-20%, 2-20%, 1-10%, 1-10%).

1_ Interfaccia di comunicazione; 2_ Alimentazione; 3_ Ingresso aria compressa.