



gygablend

Off-line batch loss in weight gravimetric blender

GYGABLEND is the unique off-line batch loss in weight gravimetric blender designed to blend multiple components simultaneously for all processes where an homogeneous mix is critical to achieve an excellent final product.

It is designed to meter from small to very large batch where huge outputs are required.



PRINCIPLE OF OPERATION

Each hopper and material is weighed by off-center load cells. Thanks to this feature all the components are metered at the same time to reach the batch set point value. The result is a massive increase in the dosing speed and a greater output in comparison to the traditional gain in weight batch blenders.

MAIN FEATURES

FAST CLEANING

GYgablend has all the side component gravimetric hoppers easily drainable so blender cleaning and production changeover has never been so fast and easy for the operator.

BLENDING

Thanks to the combination between the simultaneous dosing of all components and the special designed vertical mixer GYgablend guarantees an excellent blend.

HMI

GYgablend has its own 5.7" HMI (with 7" – 10.4" available) touch screen from which the operator can easily set parameters, calibrate the load cell and check alarms.

REMOTE ASSISTANCE

VNC is installed to allow easy remote monitoring and assistance via an internet / ethernet connection.

PNEUMATIC

Premium digital pneumatic components are connected directly via serial port to the PLC to make the installation the easiest possible and allow simple troubleshooting.

Thanks to this modular solution any future upgrade guarantees the option to increase the number of components.

CONVEYING SYSTEM

Gygablend can be supplied along with an integrated centralized conveying system controlled by the same PLC as the blender.

MODULARITY

Thanks to its design Gygablend can be upgraded in future to allow the possibility for additional components to mix, up to max 6 components.

PLC. INDUSTRY 4.0 & IoT

Gygablend has a PLC with protocol UPC/UA embedded. This solution makes each blender modular and ready for Industry 4.0.

TECHNICAL DATA

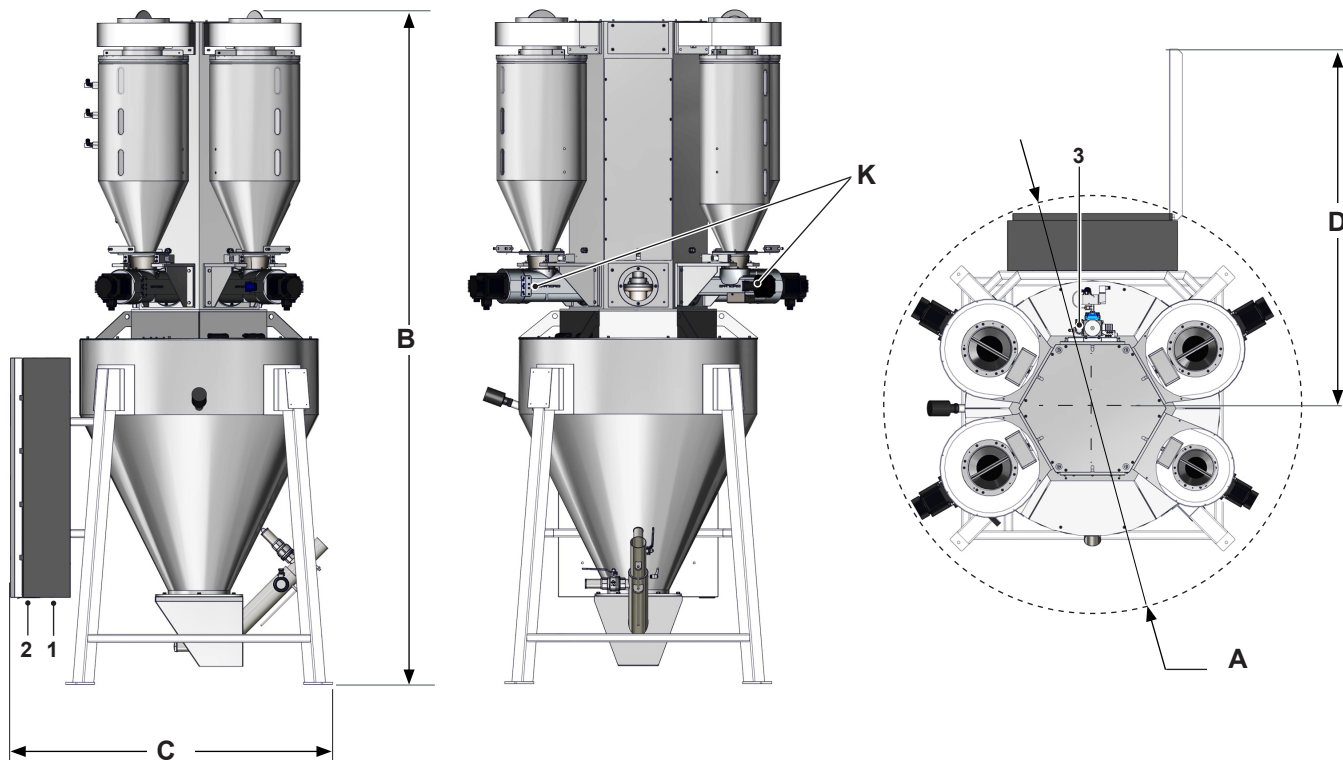

Model	XL2	XL3	XL4	XL5	XL6
Flow rate* max (kg/h)	up to 5000				
Mixer volume (L)	1000				
Suitable hopper loader model	F370 - F470				
Weight (kg)	740	820	900	980	1060
A (mm)	1910				
B (mm)	3310				
C (mm)	1620				
D (mm)	1690				2000

Dosing screws (K)						
Diameter x pitch (mm)	50 x 50	60 x 60	70 x 70	80 x 80	90 x 90	100 x100
Flow rate* @ 300 rpm (kg/h)	600	1200	-	-	-	-
Flow rate* @ 275 rpm (kg/h)			1280	-	-	-
Flow rate* @ 250 rpm (kg/h)				1540	-	
Flow rate* @ 225 rpm (kg/h)					1780	-
Flow rate* @ 200 rpm (kg/h)						1975

* Flow rate values are calculated considering the apparent density of the granule = 0,55 kg/dm³. They vary according to the grain size of the material.

1_ Communication interface; 2_ Power supply; 3_ Compressed air inlet.