



mybatch

The Innovative Weighted Batch Blender

MYBATCH is an innovative weighted batch blender, designed to dose and blend multiple components in sequence, ideal for all those processes where constant gravimetric feeding and an homogeneous mix is required.

OPERATING PRINCIPLE

Each ingredient is dosed in sequence by slide gate valves into the weighting hopper mounted on two load cells. Once the pre-set batch weight has been reached, the load cell sends a signal and the batch is unloaded into the weighting and mixing chamber which combines both the batch and the weight-loss technology.



MAIN FEATURES

GRAVIMETRIC EXTRUSION THROUGHPUT

The mixer is mounted on two load cells and measures the LIW, controlling the extrusion throughput with continuous reading.

WIDE RANGE OF SETTINGS

Thanks to the wide variety of dosing gate reductions, each component can be easily switched from low to high dosing rates.

CONVEYING SYSTEM

MYBATCH can be supplied along with an integrated centralised conveying system controlled by the same software as the blender.

CLEANING

Easy cleaning thanks to the drain spout installed on each hopper; a compressed air gun is also included.

HMI

Blender can be equipped with a HMI touch screen (5.7" - 7" - 10") onboard or supplied in a separate box.

PLC & INDUSTRY 4.0

MYBATCH has a PLC with protocol OPC/UA embedded. This solution makes each blender modular and ready for Industry 4.0.

MIXER MOTOR SYNCRO

MYBATCH uses a three phase motor for its mixer along with a dry gearbox avoiding any possible motor overheating and oil leaking.

MODULARITY

Thanks to its design MYBATCH can be upgraded in future to allow components to be increased by simply adding the surge hoppers from 2 to 6 components.

EASY MAINTENANCE

Large opening doors facilitate easy access to the machine for cleaning operations. The reliability of the machine makes it virtually "maintenance free".

SMARTDRAYN

As an option MYBATCH can be equipped with the automatic draining system SMARTDRAYN.

EASY CLEANING

As an option MYBATCH can be equipped with the mixer installed on linear guides for easy access to the mixing chamber along with the possibility of dismantling the mixer shaft for simple cleaning.

HT Version

Optionally MYBATCH can manage hot materials up to 180°C.

MODULARITY

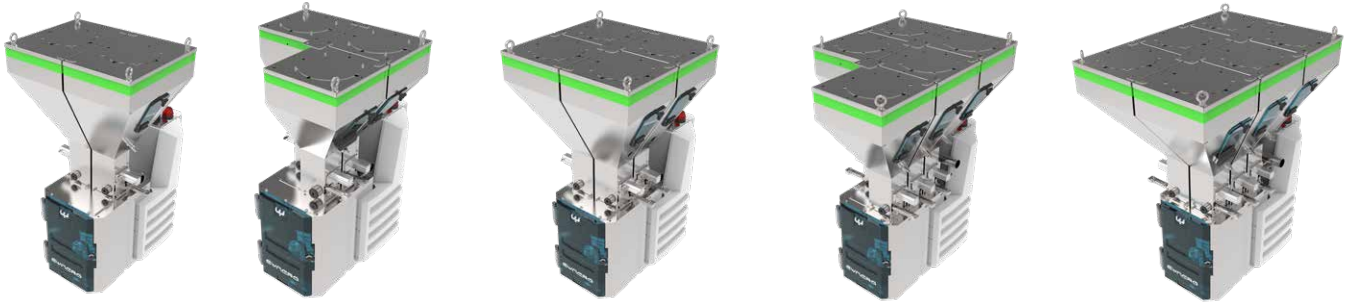

TECHNICAL DATA

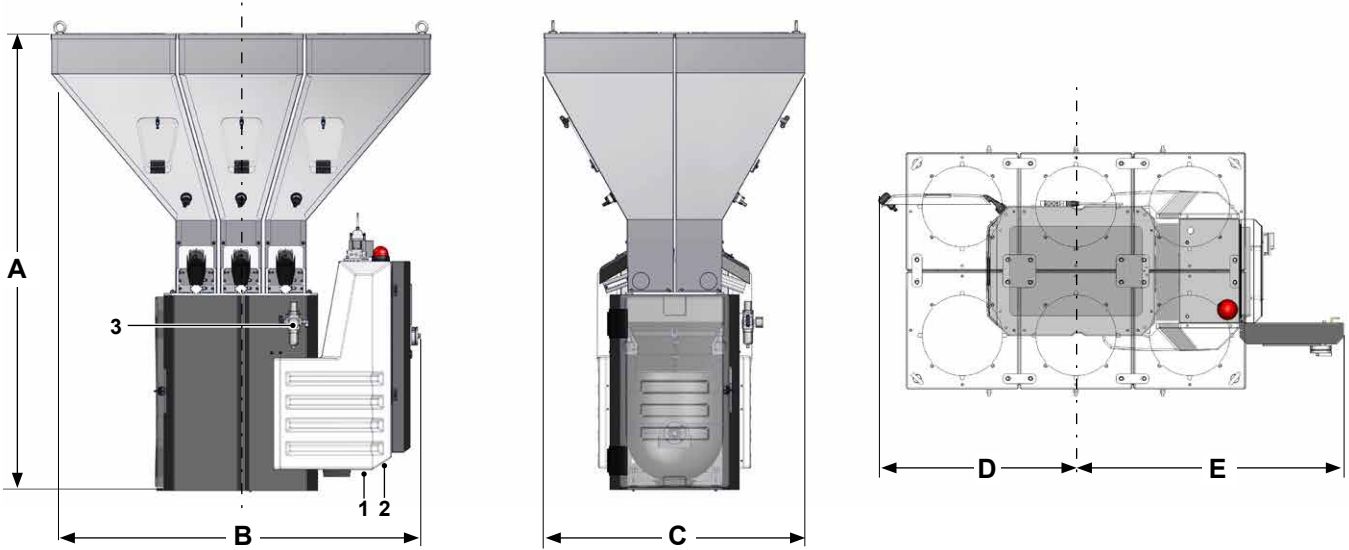

Model	S2	S3	S4	S5	S6	SP2	SP3	SP4	SP5	SP6	M2	M3	M4	M5	M6	L2	L3	L4	L5	L6
Nominal inalth throughput (kg/h)	295	275	255	230	210	400	375	350	325	300	930	865	815	740	700	1390	1301	1224	1122	1046
Max Batch Weight (kg)	2,5					4					7					12				
Gross Volum single compartment (L)	47	34				47	34				72	58				109	94			
Range of flow rates* max (kg/h) (calculated according to standard recipes)**	310 450	232 395	330 365	170 325	160 295	415 640	440 585	500 550	350 500	330 470	995 1275	790 1125	910 1020	600 915	550 835	1545 1760	1335 1600	1400 1485	1105 1360	1005 1265
Installed Power(kW)	0,9															1,13				
Consumption Power (kW)	0,6															0,8				
Consumption Compressed Air (NI/h)	85	125	165	205	245	85	125	165	205	245	100	150	200	250	300	100	150	200	250	300
Suitable MAX valve diameter (mm)	44										60									
Suitable hopper loader model	F270										F270 - F370					F270 - F370 - F470				
Weight (kg)	112	122	132	160	170	132	142	152	180	190	188	200	212	224	236	208	220	232	244	256
A (mm)	1245					1395					1580					1760				
B (mm)	860	926		1095		860	926		1095		920	1030		1312		970	1136		1582	
C (mm)	703										902					1092				
D (mm)	600										670					730				
E (mm)	800										900					960				
* * Flow rate values are calculated considering the apparent density of the granule = 0,55 kg/dm ³ ; they vary according to the grain size of the material. Screw doser possible for flow rates below 300 g/h.																				
** 2 ingredients (50-100%, 1-10%); 3 ingredients (50-100%, 2-20%, 1-10%); 4 ingredients (50-100%, 50-100%, 2-20%, 1-10%); 5 ingredients (50-100%, 50-100%, 2-20%, 1-10%, 1-10%); 6 ingredients (50-100%, 50-100%, 2-20%, 2-20%, 1-10%, 1-10%).																				
1_ Communication interface; 2_ Power supply; 3_ Compressed air inlet.																				