



skymex

Capacitive Gauging System for Blown Film Lines

SKYMEX is a capacitive thickness gauge for blown film lines. It provides a continuous profile measurement around the bubble and is installed on an patented positioning device with an oscillating ring connected to an auto profile control.

PRINCIPLE OF OPERATION

SKYMEX is based on capacitive technology. Dielectric characteristics of the film that is in contact with the sensor, produce a variation of the signal proportional to the film thickness.



MAIN FEATURES

PATENTED TRIPLE TELESCOPIC SYSTEM

The triple telescope is based on a movement mechanism that makes the positioning of the sensor precise and safe, overcoming the common stability problems of classic systems on the market (Patent WO2015/155621).

The telescopic beam on which the sensor is mounted is positioned on two carriages that move simultaneously around the extruded bubble.

Skymex meets 4 fundamental requirements of the designers: rigidity, absence of vibrations, large radial measuring radii and minimum overall dimensions during rotation.

Skymex has no radial overhang and no intermediate "junctions" between the bogies.

BELT FREE MOTION

Movement is "belt free" so no maintenance or belt replacement is required.

AVAILABLE UP TO 14 METER LAYFLAT

SKYMEX is available in different sizes up to 14 mt lay flat.

BIG MIN-MAX RATIO

Thanks to its patent triple telescopic device oscillating ring SKYMEX is able to guarantee 4 ÷ 1 ratio between minimum and maximum bubble diameter.

ULTRASONIC DISTANCE SENSOR

SKYMEX is equipped with an ultrasonic sensor for keeping the distance from sensor to bubble always constant.

360° ENCODER BAND

SKYMEX is equipped with a 360° encoder band which allows to know the angular position with the maximum precision.

360° ROTATION SYSTEM

As option SKYMEX can rotate continuously at 360° in one direction thanks to a powered rail and an industrial Wi-Fi.

INDUSTRY 4.0 & IoT

SKYMEX is equipped with PLC integrated with OPC-UA protocol for industry 4.0.

TECHNICAL DATA

Minimum layflat

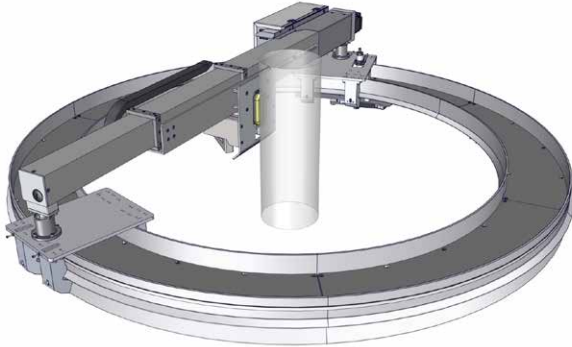

Maximum layflat

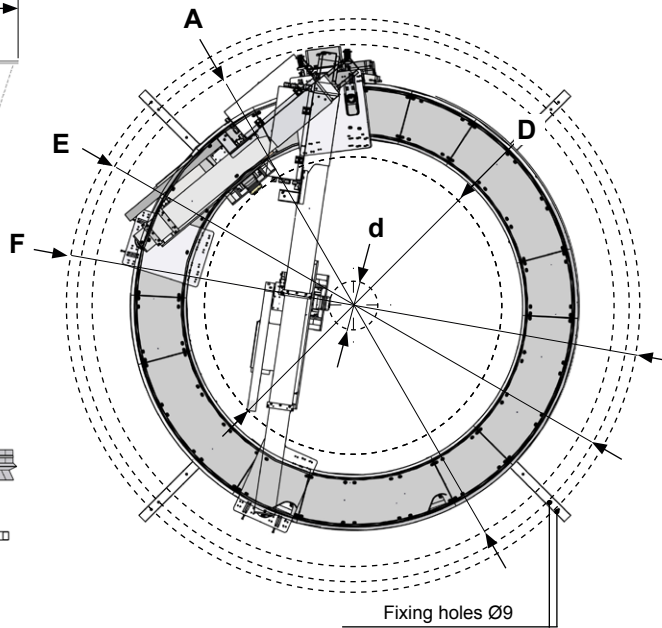
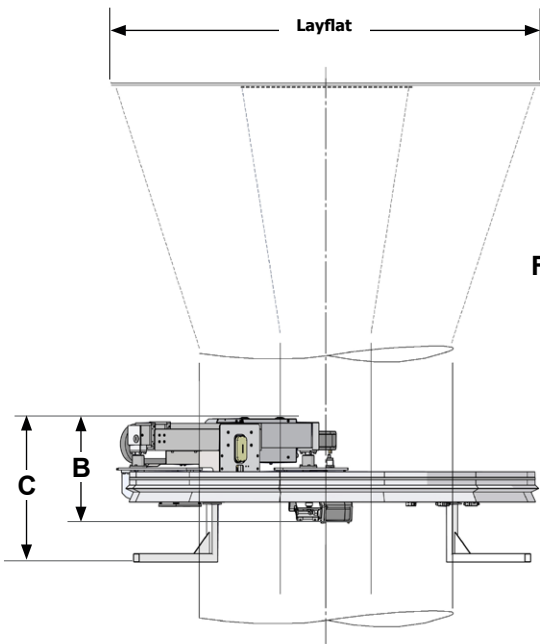
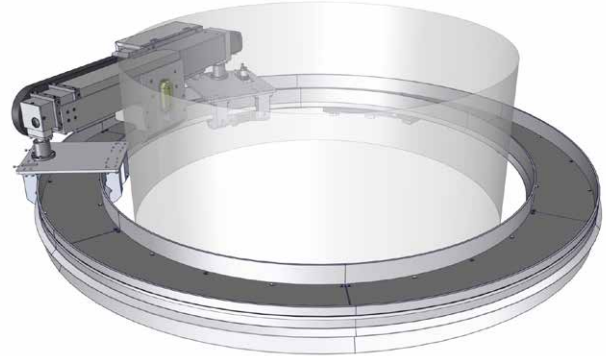

Control box

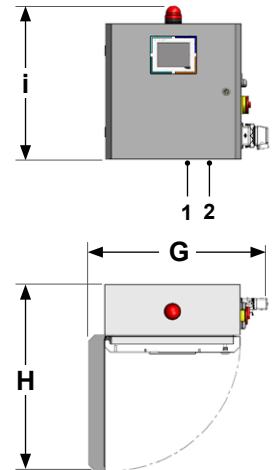

Model	Layflat		Ø A (mm)	B (mm)	C (mm)	Ø d (mm)*	Ø D (mm)*	Ø E (mm)	Ø F (mm)	G (mm)	H (mm)	i (mm)	Power (kW)	Weight (kg)
	LF min*	LF max*												
250-1650	250	1650	2250	500	625	159	1050	2385	2475	660	685	565	0,5	130
450-1900	450	1900				286	1210							150
500-2550	500	2550	318			1624	175							
750-2750	750	2750	477			1751	230							
875-3500	875	3500	557			2229	3609,5	3699,5	280					
1125-4500	1125	4500	**		716	2866	**	**	300					
1400-5600	1400	5600	5050	**	891	3566	**	**	360					
1800-7200	1800	7200	6220	658	**	1146	4585	**	**	520				

* Indicates the cold film, during processes the diameter could be increased up to 5%.

** Values to be defined depending on the production.

1_ Communication interface; 2_ Power supply;