



Syacurablend

Off-line loss in weight gravimetric blender

SYACURABLEND is an off-line batch loss in weight gravimetric blender designed to blend multiple components simultaneously for all processes where a homogeneous mix is critical to achieve an excellent final product. Thanks to its unique design it can be installed on the ground floor or on the mezzanine to prepare a blend of components to be delivered to the extruder. Ideal for premixing of additives or where a minimum blend storage is required.

PRINCIPLE OF OPERATION

The ingredients are continuously and simultaneously metered directly in the integrated mixing chamber through a cascade static mixer. Thanks to the big mixer chamber volume, a perfect mixing of the components is guaranteed. The blend can be then conveyed on the next step of the process or discharged in a gravimetric hopper for extrusion control or in another dosing unit.



MAIN FEATURES

PLC. INDUSTRY 4.0 & IoT

Syacurablend has a PLC with protocol UPC/UA embedded. This solution makes each blender modular and ready for Industry 4.0.

CONVEYING SYSTEM

Syacurablend can be supplied along with an integrated centralized conveying system controlled by the same PLC as the blender.

MODULARITY

Thanks to its design Syacurablend can be upgraded in future to allow the possibility for additional components to mix, up to max 6 components.

EXTREMELY LOW %

Syacurablend system can dose down to 100 gr/h.

FLEXIBILITY

Syacurablend can run up to 100 % with all its components.

BLENDING

Thanks to its innovative cascade static mixer and a motorized screw mixing device positioned into the main mixer chamber Syacurablend guarantees a perfect blend.

CLEANING

Syacurablend components all have removable gravimetric hoppers, so blender cleaning and production changeover has never been as fast and easy for an operator.

HT VERSION

As option Syacurablend can manage hot materials up to 180°C.

INTEGRATED IN SYNTROL

As all SYNCRO dosing units Syacurablend can be connected and controlled by supervisory system SYNTROL.

TECHNICAL DATA

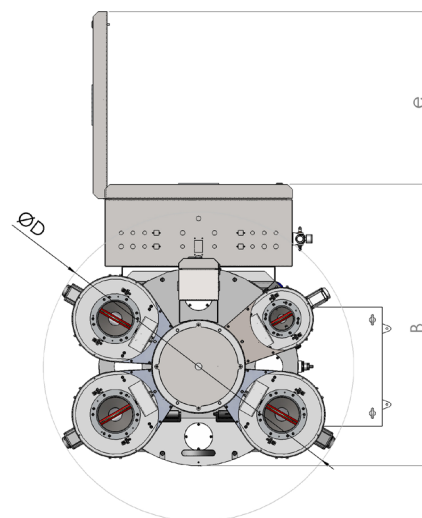
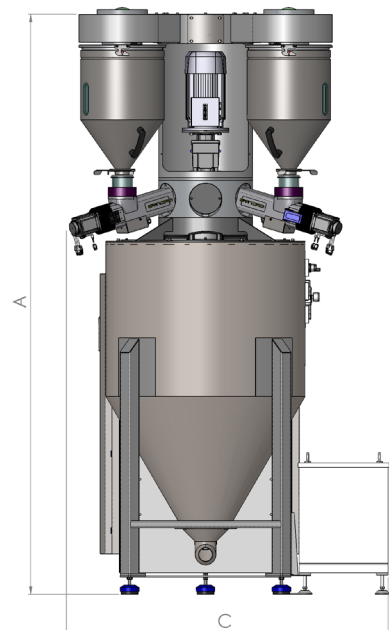

		S	M	L
Number of components		up to 6	up to 6	up to 6
Suitable hopper loaders		F270	F270 - F370	F270 - F370
Troughput	Kg/h	250	500	1000
Mixer volume	L	380	500	800
Dimension A	mm	2415	2500	3000
Dimension B	mm	1250	1250	1300
Dimension C	mm	1350	1350	1925
Dimension D	mm	1250	1350	1350
Dimension e	mm	650	750	750
Weight	Kg	450	500	550