



SYBLEND

The continuous loss-in-weight gravimetric Blender

SYBLEND is a continuous loss in weight gravimetric blender designed to blend multiple components simultaneously for all processes where a homogeneous mix is critical to achieving an excellent final product. It meets all the need of a highly demanding process as per BCF, FDY and POY. Each hopper and material is weighed by two off-center load cells.

PRINCIPLE OF OPERATION

All the ingredients are continuously and simultaneously metered directly in the integrated weight collection hopper through a cascade mixer. The weight of the material metered in the collection hopper is constantly measured in order to detect the level variations due to changes in the extruder throughput or a discrepancy between the component feeder and the extruder throughput. The feeders are individually controlled in order to reach and maintain the preset metering ratios and to maintain a constant level in the collection hopper. As a result the metered throughput of the combined components is always equal with that of the extruder throughput.



MAIN FEATURES

CLEANING

SYBLEND has all the side component gravimetric hoppers removable, so blender cleaning and production changeover has never been so fast and easy for an operator.

ACCURACY AND VIBRATION

SYBLEND has 2 loads cells for each component to negate vibration and to have better stability and improve the accuracy of dosing.

HMI

Every blender has its own 5.7" HMI touch screen from which the operator can easily set the parameters, calibrate the load cell and check the alarms. VNC is installed to allow easy remote monitoring via an internet / ethernet connection.

CONVEYING SYSTEM

SYBLEND can be supply along with an integrated centralised conveying system controlled by the same PLC as the blender.

MODULARITY

Additional components can be added in the future if required, allowing for an easy upgrade to existing blenders – up to max. 6 components.

PLC & INDUSTRY 4.0

SYBLEND has a PLC with protocol UPC/UA embedded. This solution makes each blender modular and ready for Industry 4.0.

HT VERSION

Version As option MYBLEND can manage hot materials up to 180°C.

100% TECHNOLOGY

Each SYBLEND component including the main material, is dosed using a dedicated screw. This guarantees the maximum flexibility and allows all components to run up to 100% of their set point.

MODULARITY



TECHNICAL DATA

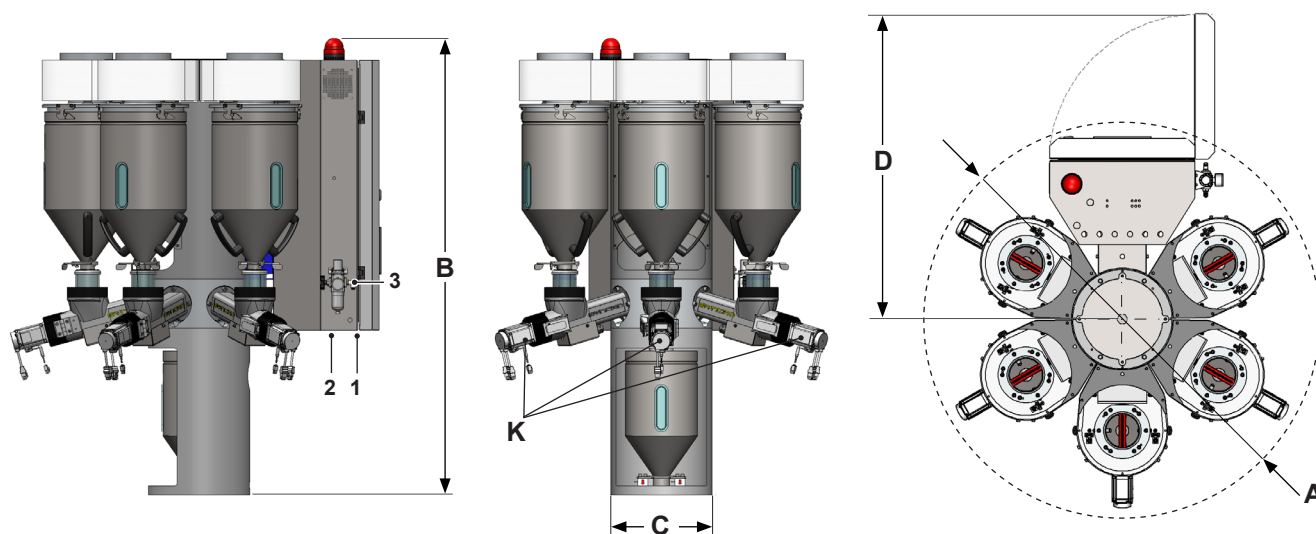

Model	S2*	S3*	S4*	S5*	S6*	M2	M3	M4	M5	M6	L2	L3	L4	L5	L6	
Nominal troughput (kg/h)	250					500					1000					
Max capacity** single component (kg/h)	550					1150					1880					
Single hopper volume (dm ³)	16,7					35,2					57,0					
Installed power (kW)	1	1,4	1,8	2,2	2,6	1,7	2,5	2,9	3,3	3,65	2,2	3,2	4	4,7	5,45	
Suitable hopper loaders	F270					F270 - F370										
Working temperature (°C)	0 - 40															
Storage temperature (°C)	-10 - 60															
Pneumatic working pressure (bar)	6															
Weight (kg)	220	245	270	295	320	250	275	300	325	350	280	310	340	370	400	
Ø A (mm)	1160					1380										
B (mm)	1360					1480					1770					
Ø C (mm)	300					400										
D (mm)	900				1220	950				1220		950			1220	

Dosing screws (K)

Diameter x pitch (mm)	10 x 8	10 x 10	15 x 10	15 x 15	20 x 20	25 x 25	30 x 30	40 x 40	50 x 50	60 x 60	70 x 70
Flow rate** @ 450 rpm (kg/h)	23	28	50	75	110	220	320	600	1000	1500	2050
Flow rate** @ 5 rpm (kg/h)	0,1	0,4	0,6	1	1,3	2,9	3,5	7	11,5	17	25

* For S models, possible dosing screws range from 10 x 8 to 40 x 40.

** Flow rate values are calculated considering the apparent density of the granule = 0,55 kg/dm³. They vary according to the grain size of the material.

1_ Communication interface; 2_ Power supply; 3_ Compressed air inlet.