



tphoon

Dual lip automatic air ring

TYPHOON, is the new automatic air ring designed for high efficiency and accurate profile control.

The air ring guarantees the best performances in term of cooling capacity, bubble stability, minimum pressure drop, and easy handling.

PRINCIPLE OF OPERATION

TYPHOON provides segmented airflow to localized areas around the blown film bubble through the air ring while stabilizing the film exit thanks to the special lip set. The automatic thickness improvement system offers simplicity and state-of-the-art visualization giving the highest operational reliability.

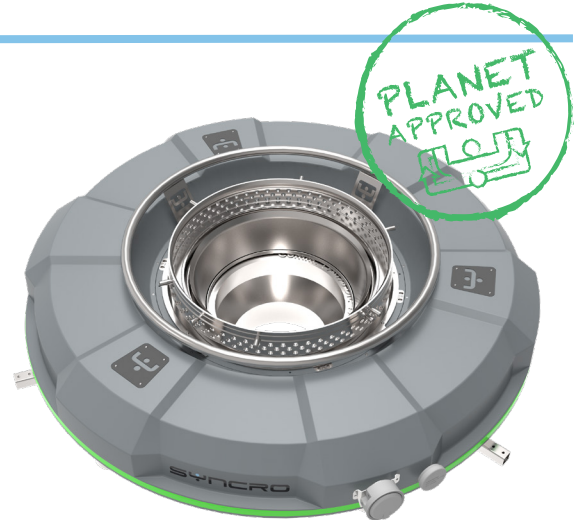

MAIN FEATURES

EASY INSTALLATION

TYPHOON can easily replace an existing air ring improving the performances of the line such as throughput and profile control.

OPTION DOUBLE LAYER CARBON FIBRE CHAMBER WITH SINGLE AIR INLET

As an option, TYPHOON's chamber can be supplied with a double carbon fibre skin and an insulation layer in the middle to achieve moisture free operation. The carbon fibre chamber version has one air inlet in order to have a clean area around the die for easy maintenance.

OPTIONAL LIFTING SYSTEM

Typhoon as an option can be equipped with a lifting system managed by the SYNTROL supervision system that allows the storage of the positioning in the recipe of the product reducing to a minimum the recipe change times. The lifting system is also essential for easy and quick maintenance and cleaning of the extrusion head.

EASY ACCESS FOR MAINTENANCE

TYPHOON has been designed to guarantee easy access for maintenance operations.

INDUSTRY 4.0 & IoT

All Syncro machines are ready to be integrated with third party supervisory controls and ERP systems using the latest generation of OPC-UA protocols as standard.

BOOSTER STABILIZER

A booster stabilizer is available for better bubble stability and higher output.

TECH 2.0

Extreme Performances on Auto Profile Control, TYPHOON is available with air volume and temperature control working together in order to reduce the original profile deviation. With Tech 2.0, TYPHOON has one motor and two heaters for each control point and it can achieve up to an 75% reduction of starting profile deviation.

BIG BUR RANGE

TYPHOON is suitable for large and small BUR thanks to its innovative and dedicated lip-set design.

AGRI FILM APPLICATION

TYPHOON is suitable for Agri Film applications and is available for extrusion die diameters of up to 2500 mm.

TECHNICAL DATA

Aluminium version (Al)

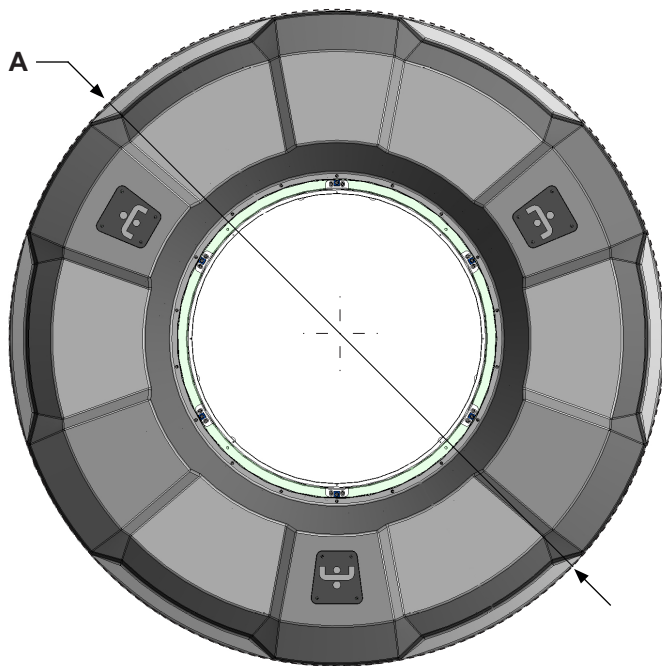
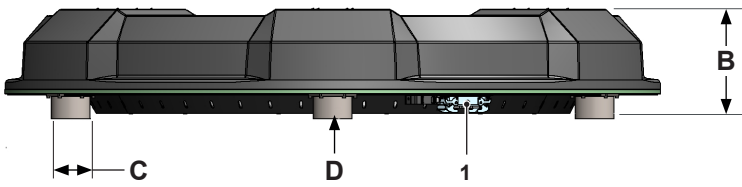

Carbon fiber version (C)

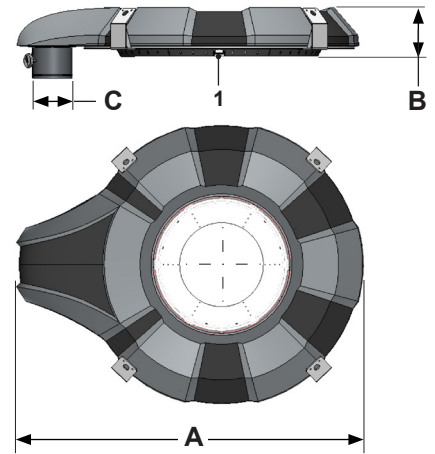

Lifting system optional

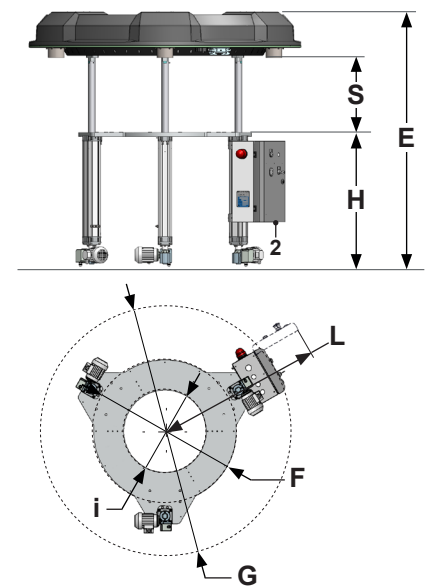

Model	Die Range (mm)	Control points (n°)	Heater (n°)	A (mm)	B (mm)	Ø C (mm)	D (n°)	E (mm)	Ø F (mm)	Ø G (mm)	H (mm)	Ø i (mm)	L (mm)	S Stroke (mm)	Power (kWh)	Weight (kg)	
Y1 (Al)	150÷250	32	64	Ø1455	275	101,6	4	1600	665	1335	875	300	920	25-450	15	310	
Y2 (Al)	200÷500	48	96	Ø1720			6		940	1620		520	1060		22,5	380	
Y3 (Al)	450÷650	64	128	Ø1930			8		1140	1820		700	1160		30	470	
Y4 (Al)	650÷950	88	176	Ø2250			10		1460	2140		1100	1320		41	650	
Y5 (Al)	850÷1500	120	240	Ø2600	380	12	1700	2000	2600	1600	1550	56	870				
Y1 (C)	150÷250	32	64	1720	300	200	-	1600	665	1335	875	300	920	25-450	16	250	
Y2 (C)	200÷500	48	96	2150		250			940	1620		520	1060		23,5	380	
Y3 (C)	450÷700	60	120	2380		318			300	1140		1820	700		1160	29	530
Y4 (C)	650÷950	88	176	2880		450			350	1460		2140	1100		1320	42	585

All dimensions refer only to the air ring without insert.

1_ Air ring power supply; 2_ Lifting system power supply.