



# DEFEX

## Lump & neckdown detection

**DEFEX** is the newest generation optoelectronic device for non-contact in-line measurement and identification of surface defects on wires, cables and pipes such as protrusions, throttling, abrasions, local insulation lack and partial detachments or flakes.

### OPERATING PRINCIPLE

The LED source emits a collimated beam across the central area so that the passing cable projects a shadow: the linear high-resolution CCD on the other side reads the trough-beam with very high frequency and continuously evaluates the entity of the shadow, which is equivalent to the diameter in that plane, while the cable travels.

By monitoring the diameter the defects can be spotted as change in the measured value, alarming and reporting the height, length and location of lumps and necks along and around the product, and from their shape they can also be categorized.



### MAIN FEATURES

#### ABSOLUTE PERFORMANCE

Due to the nature of the CCD, no calibration is required and the signal will always be the absolute measure of the diameter independently on the cable, wire or pipe nature, material or geometry.

#### ULTRA-FAST READINGS

DEFEX can produce up to 200.000 readings per second, ensuring that in the span of a single defect many point-like measurements can be taken even in the fastest lines and thus tracing its profile accurately, without risk of losing info in-between readings.

#### POWERFUL ANALYSIS SOFTWARE

DEFEX can perform data analysis at the same speed of its measurements, therefore it can evaluate and categorize any defect as soon as it passes through the beam, immediately reporting the position of the defect, its type and magnitude. The ultra-fast reading ensures that defects as small as 40 µm in height can be detected and analyzed. The software also saves the position of the defects, allowing for the unwinding of the cable to the various faults' positions.

#### LONG-LIFE RELIABILITY

DEFEX is designed with solid-state devices and no moving parts, so that the absence of wear and drift allows for long-life performance without maintenance needed.

#### FUNCTIONAL DESIGN

The lower aperture grants easy installation in the production line together with other operations such as product changes, and allows condensation, dirt and dust to fall away instead of accumulating in the reading zone.

#### INDUSTRY 4.0 & IoT

DEFEX is equipped with an integrated interface so that it can work as a stand-alone device, but due to its TCP/IP protocol it can also easily communicate with any PLC or supervisor through a simple software package, making it ready for remoting and Industry 4.0

TECHNICAL DATA

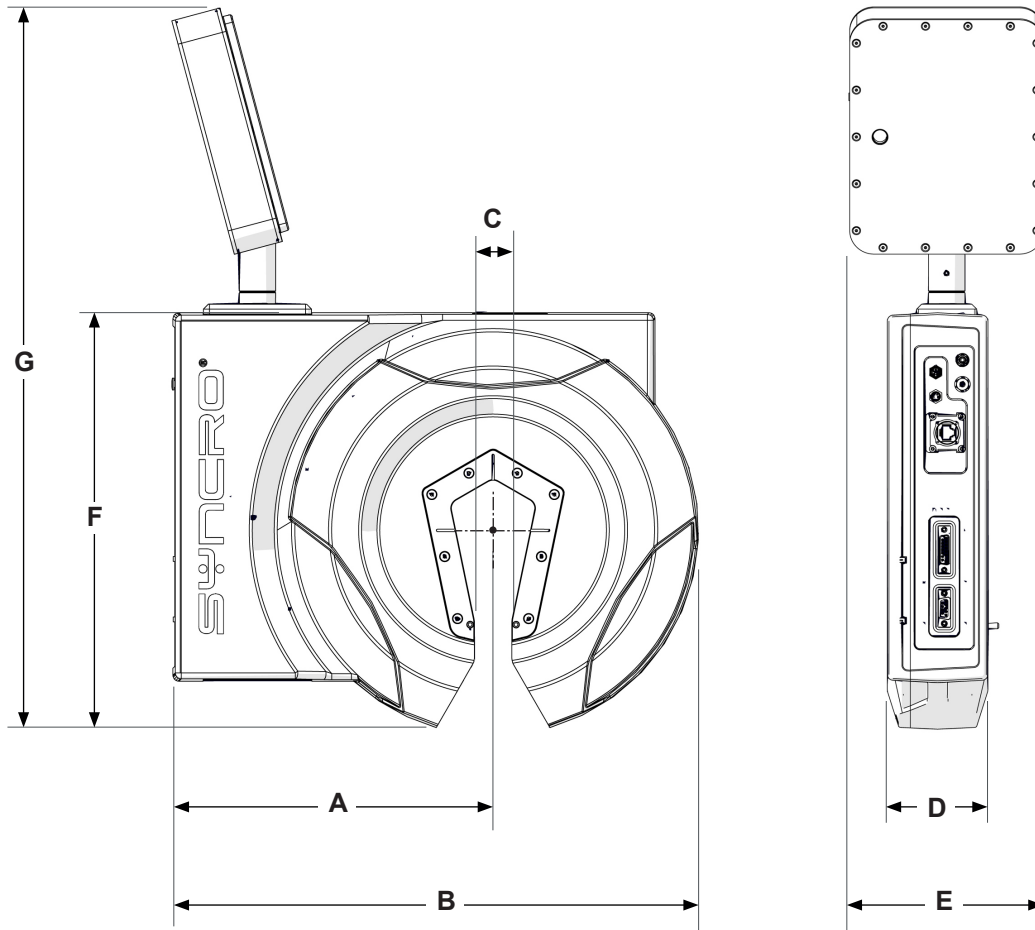

	A	B	C	D	E	F	G
<b>Dimension</b>	265 mm	435 mm	30 mm	85 mm	160 mm	345 mm	600 mm
<b>Number of axes</b>	up to 3						
<b>Minimum Diameter</b>	0,04 mm						
<b>Maximum Diameter</b>	25 mm						
<b>Minimum fault height</b>	0,04 + 1% of object diameter						
<b>Minimum fault length</b>	0,5 mm						
<b>Tolerance setting range</b>	0,04 to 10 mm (0,001 increments)						
<b>Tolerance setting resolution</b>	0,01 mm						
<b>Maximum speed</b>	2500 m/min, dependent un fault length						
<b>Minimum time between faults</b>	20 microseconds						
<b>Signal processing rate</b>	200 kHz						
<b>Power requirement</b>	15-25 vdc, 20 W max						
<b>Protection rating</b>	IP67						
<b>Temperature range</b>	5°C - 40°C (41°F - 104°F)						