



## sydos

# The continuous loss-in-weight gravimetric Blender

**SYBLEND** is a continuous loss in weight gravimetric blender designed to blend multiple components simultaneously for all processes where a homogeneous mix is critical to achieving an excellent final product. It meets all the need of a highly demanding process as per BCF, FDY and POY. Each hopper and material is weighed by two off-center load cells.

### PRINCIPLE OF OPERATION

All the ingredients are continuously and simultaneously metered directly in the integrated weight collection hopper through a cascade mixer. The weight of the material metered in the collection hopper is constantly measured in order to detect the level variations due to changes in the extruder throughput or a discrepancy between the component feeder and the extruder throughput. The feeders are individually controlled in order to reach and maintain the preset metering ratios and to maintain a constant level in the collection hopper. As a result the metered throughput of the combined components is always equal with that of the extruder



### MAIN FEATURES

#### CLEANING

Sydos has all the side component gravimetric hoppers removable, so blender cleaning and production changeover has never been so fast and easy for an operator.

#### ACCURACY AND VIBRATION

Sydos has 2 loads cells for each component to negate vibration and to have better stability and improve the accuracy of dosing.

#### HMI

Every blender has its own 5.7" HMI touch screen from which the operator can easily set the parameters, calibrate the load cell and check the alarms. VNC is installed to allow easy remote monitoring via an internet / ethernet connection.

#### CONVEYING SYSTEM

SYblend can be supply along with an integrated centralised conveying system controlled by the same PLC as the blender.

#### MODULARITY

Thanks to its design MYBATCH can be upgraded in future to allow components to be increased by simply adding the surge hoppers from 2 to 6 components.

#### PLC & INDUSTRY 4.0

Syblend has a PLC with protocol UPC/UA embedded. This solution makes each blender modular and ready for Industry 4.0.

#### HT VERSION

Optionally Syblend can manage hot materials up to 180°C.

## MODULARITY



## TECHNICAL DATA

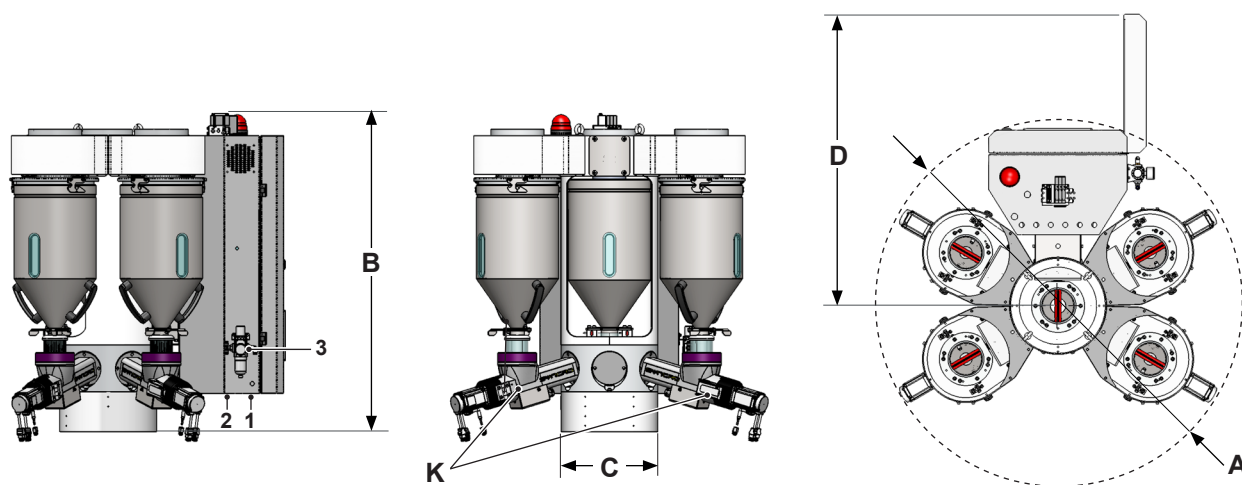

Model	S2*	S3*	S4*	S5*	S6*	S7*	M2	M3	M4	M5	M6	M7	L2	L3	L4	L5	L6	L7		
Capacity** max. main component (kg/h)	550						1100						1850							
Capacity** max. single side component (kg/h)	550						550						940							
Main hopper volume (dm <sup>3</sup> )	16,7						35,2						57,0							
Single side hopper volume (dm <sup>3</sup> )	16,7						16,7						25,8							
Installed power (kW)	1	1,4	1,8	2,2	2,6	3,0	1,7	2,5	2,9	3,3	3,65	4,1	2,2	3,2	4	4,7	5,45	5,85		
Suitable hopper loaders	F270						F270 - F370													
Working temperature (°C)	0 - 40																			
Storage temperature (°C)	-10 - 60																			
Pneumatic working pressure (bar)	6																			
Weight (kg)	150	175	205	235	265	295	175	190	215	245	275	315	205	235	265	295	325	355		
Ø A (mm)	1160						1280						1380							
B (mm)	920						1000						1240							
Ø C (mm)	300						400													
D (mm)	900						1220		950				1220		950				1220	

### Dosing screws (K)

Diameter x pitch (mm)	10 x 8	10 x 10	15 x 10	15 x 15	20 x 20	25 x 25	30 x 30	40 x 40	50 x 50	60 x 60	70 x 70
Flow rate** @ 450 rpm (kg/h)	23	28	50	75	110	220	320	600	1000	1500	2050
Flow rate** @ 5 rpm (kg/h)	0,1	0,4	0,6	1	1,3	2,9	3,5	7	11,5	17	25

\* For S models, possible dosing screws range from 10 x 8 to 40 x 40.

\*\* Flow rate values are calculated considering the apparent density of the granule = 0,55 kg/dm<sup>3</sup>. They vary according to the grain size of the material.

1\_ Communication interface; 2\_ Power supply; 3\_ Compressed air inlet.