



# Hopper Loader

**CONVY** is SYNCRO's range of hopper loaders made out of stainless steel AISI 304 and available in different sizes. Loading parameters can be controlled by the dosing unit HMI or centralized conveying system SYNET. Convy range includes specific options for the treatment of high temperature or low flowing materials.



## PRINCIPLE OF OPERATION

The vacuum created by the vacuum unit convey the granules into the receivers, once the max level is achieved the material is discharged into the hopper.

## MAIN FEATURES

### CONTROL

Convy can be controlled from SYNCRO's dosing unit HMI panel or from the centralized conveying system SYNET

### EASY INSTALLATION

Convy can easily be installed on existing dosing units.

### EASY CLEANING

Thanks to its special design Convy can be easily cleaned and disassembled.

### VACUUM VALVE

Convy has an integrated vacuum valve which opens when the vacuum is required, allowing for the use of a common vacuum pipe connected to a pump.

### DISCHARGE GASKET

Convy has a special discharge gasket which allows perfect sealing during the vacuum cycle.

### MAX LEVEL SENSOR

Convy has an integrated capacitive max level sensor which ensures the max volume is available at any given time in order to guarantee the best optimization of the conveying cycle time. As an option, a rotary sensor can be used for dusty materials.

### AUTO FILTER

As an option Convy can be supplied with self-cleaning filters with an air tank and air pulse cleaning jet.

### BAG AUTO FILTER

As an option Convy can be supplied with a bag self-cleaning filter with an air tank and air pulse cleaning jet in order to manage dusty material such as regrind materials or flakes.

### HT VERSION

Convy is available in an HT version in order to manage hot polymers up to 180 °C.

### SIZES & VOLUME

Convy is available in 4 sizes: F200-F270-F370-F470 from 6L to 150L.

### MODULARITY & INLET ORIENTATION

The Convy design is modular, vacuum and material inlet positions can be easily oriented to match a customer's needs.

### NAS SYSTEM

As an option Convy can be supplied with a paddle (+NAS) located on the material inlet pipe to allow the sharing of a common material source.

### TA VERSION

Convy can be supplied without a discharge paddle so it can be perfectly matched with the SYNCRO SYLINE-SYDOS-SYBLEND-SYACURABLEND and GYGABLEND series of systems for perfect integration. With the TA version the vacuum sealing is guaranteed directly from the dosing unit butterfly refill valve.

## TECHNICAL DATA

Hopper loader version

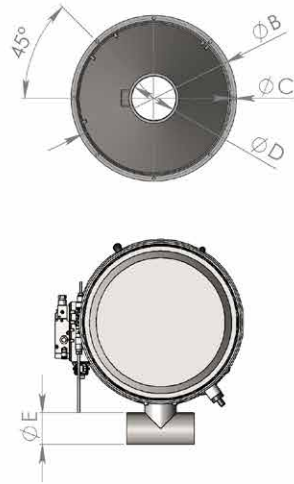
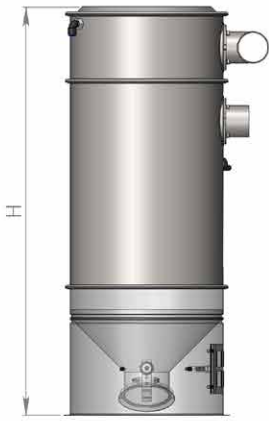

Receiver version

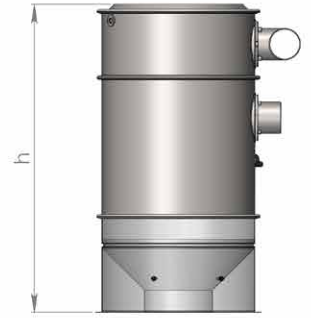

		F200			F270			F370			F470		
<b>Nominal volume</b>	L	6	9	12,5	13	19	25	25	37	50	80	100	150
<b>External diameter</b>	A (mm)	200			270			370			470		
<b>Fixing holes diameter</b>	B (mm)	185			255			355			455		
<b>Number of holes and diameter</b>	C (mm)	7,5 / 4 holes			7,5 / 8 holes			7,5 / 8 holes			7,5 / 8 holes		
<b>Total height TA version</b>	h (mm)	687	836	980	690	840	985	690	840	985	995	1135	1475
<b>Total height PA version</b>	H (mm)	757	906	1050	760	910	1055	760	910	1055	1065	1205	1545
<b>Discharge diameter</b>	D (mm)	50			100			100-150			150-200		
<b>Flex hose diameter</b>	E (mm)	40-50-60-63.5-70-76			40-50-60-63.5-70-76			40-50-60-63.5-70-76			40-50-60-63.5-70-76		
<b>Weight TA version</b>	kg	9	9,5	10	13	13,5	14	19	20	21	25	30	32
<b>Weight PA version</b>	kg	10	10,5	11	14,5	15	15,5	21	22	23	27	32	35
<b>Compressed air consumption (6 bar)</b>	NI/h	180			180			360			360		