



TYPHOON³

Automatic air ring with outstanding performance

TYPHOON³, is the cooling ring designed for maximum cooling capacity, productivity, bubble stability, accurate thickness profile control and film quality. Typhoon3 represents a true evolutionary step of the cooling ring, justifying the ambitious expression 'cubed'.



PRINCIPLE OF OPERATION

Special internal aerodynamic turbulators (patent pending) make it possible to obtain, simultaneously and for each flow regime envisaged in the use of the ring, a set of conditions such as: optimized cooling air distribution along the circumference of the blower nozzles (exclusive SYncro patent); homogeneous filling of the radial channels and regulation devices; maximum efficiency, i.e. limitation of pressure drops to the lowest possible value.

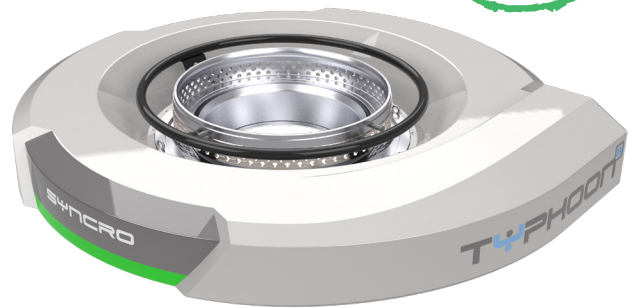

MAIN FEATURES

EASY INSTALLATION

Typhoon³ can easily replace an existing air ring, improving line performance in areas such as flow rate and profile control with an average ROI (return on investment) of 6-9 months.

FIBREGLASS CHAMBER

The machine body is natively and fully insulated as it is made of resin and fiber. This ensures high energy efficiency and prevents condensation from forming. The air supply is single-vented tangential. Connecting the ring to the chilled air system is thus simple and the operating space around the machine is improved, facilitating maintenance operations around the head.

LIFTING SYSTEM

The Typhoon³ is also available in an elevating version, managed by the SYNTROL supervision system, which allows the positioning in the product recipe to be memorized, reducing recipe change times to a minimum. The lifting system is also essential for easy and quick maintenance and cleaning of the extrusion head.

EASY ACCESS FOR MAINTENANCE

Typhoon³ is designed for easy maintenance by allowing access to both motors and heating elements without ever having to stop the extrusion line, keeping the ring in 'automatic' mode.

MULTI-STAGE STABILISER

A booster stabilizer is available for better bubble stability and higher output.

TECH 2.0

Profile adjustment is available in a Tech 2.0 version protected by a specific patent. Temperature control and point-to-point air volume control along 360 degrees of the bubble's circumference are available in alternative or complementary form for maximum flexibility in handling and control capabilities. The combination of the two technologies allows a reduction of up to 75% of the initial profile error.

LARGE RANGES OF INFLATION RATIOS

Typhoon³ is suitable for both large and small BUR thanks to its flexible design and dedicated inserts.

INDUSTRY 4.0 & IoT

All SYncro machines are ready to be integrated with third party supervisory controls and ERP systems using the latest generation of OPC-UA protocols as standard.

TECHNICAL DATA

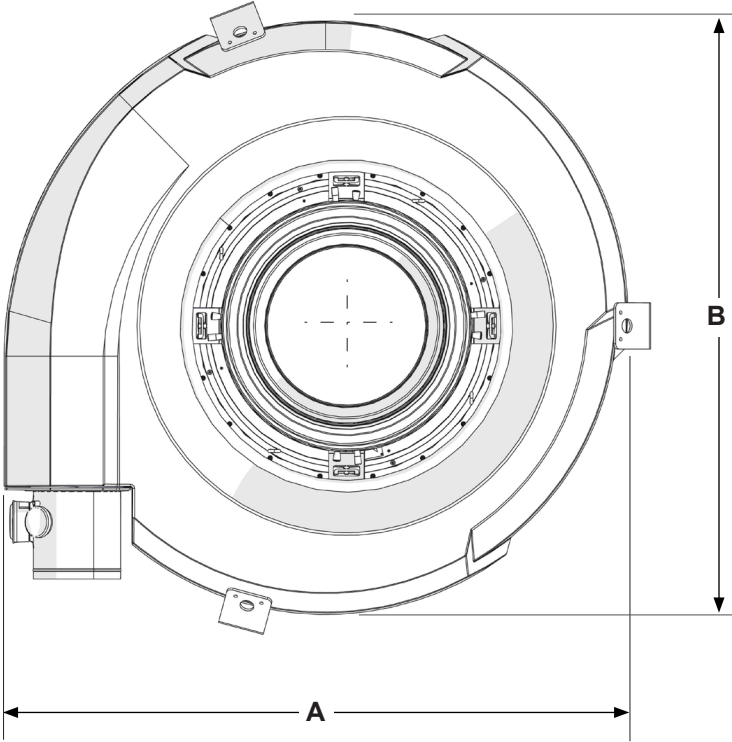
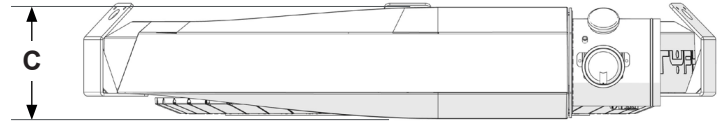
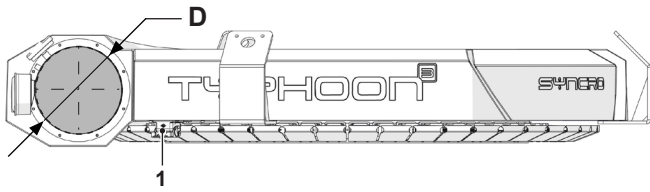

Lifting system (optional)

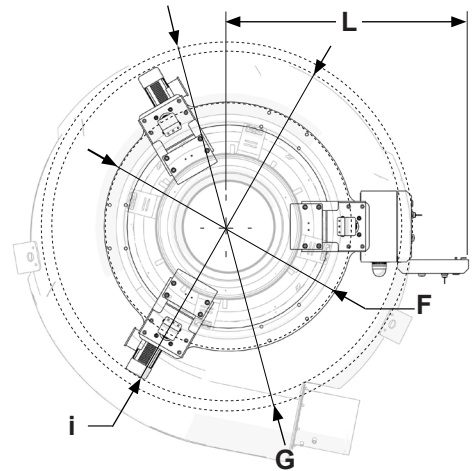
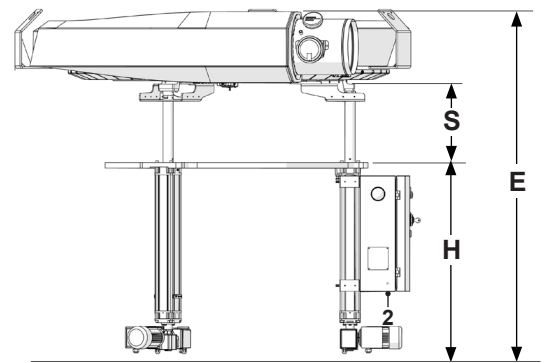

Model	Die Range (mm)	Control points (n°)	Heater (n°)	A (mm)	B (mm)	C (mm)	Ø D (mm)	E (mm)	Ø F (mm)	Ø G (mm)	H (mm)	Ø i (mm)	L (mm)	S Stroke (mm)	Power Heater (kWh)	Weight (kg)
Y00	40÷100	18	36*	640	610	200	100	**						6,5	35	
Y0	75÷170	28	56	1000	1000	250	150	**						10	120	
Y1	150÷300	36	72	1500	1500	325	215	1650	815	1335	875	1095	920	25-450	25	220
Y2	250÷500	48	96	1800	1800	350	250	1675	1090	1620		1370	1060		33	300
Y3	450÷750	64	128	2250	2250	400	300	1725	1290	1820		1570	1160		44	480

All dimensions refer only to the air ring without insert.

*Resistance-only version available. **Lifting system available in customised version.

1_ Air ring power supply; 2_ Lifting system power supply.