



CONVY-S

Single Phase Hopper Loader

When the quantity of Plastic Material to convey is small and the suction point is close to the transforming machine, the Convy-S Single Phase Hopper Loader is the right choice.

In stainless steel, with several options and available in different sizes. Loading parameters can be controlled directly with its own integrated controller.



PRINCIPLE OF OPERATION

The vacuum generated by the blower unit conveys the granules into the receiver; once the max level is achieved the material is discharged into the hopper. If present, the PVB proportional valve allows the suction of two different sources of materials (for example Virgin and regrind) from 0 to 100% and vice versa.

MAIN FEATURES

CONTROL

The Convy-S includes a powerful micro-processor control, complete with a synoptic panel, where it is possible to follow every working phase in real time. Anyway only few parameters are necessary for the complete control.

EASY INSTALLATION

The Convy-S can easily be installed with eight bolts, and can be rotated every 45° for the best orienting and positioning.

EASY FILTER CLEANING

Because of lack of stagnation points the Convy-S can be easily cleaned and disassembled.

Moreover, the Convy-S has an integrated self filter-cleaning activated at the end of every loading cycle. An integrated bag filter in polyester with a high filtration surface is also utilized to keep the air at exit clean.

DISCHARGE GASKET

The Convy-S has a special discharge gasket which allows perfect sealing during the vacuum cycle.

CALL SENSOR

The Convy-S has a level sensor integrated to the flap. When active, the loader automatically refills itself.

OPTIONS

PVB PROPORTIONAL VALVE

It is possible to program it, in order to convey alternatively 2 different materials (In example raw material and regrind), at different percentages.

SUCTION PROBE

Single pipe suction probe, in AISI 304 stainless steel.

FLEXIBLE HOSE

Antistatic high resistance or HT/FDA approved model flexible hose.

ADAPTING SUPPLEMENTARY SUPPORT

Supplementary cross type adapter to fit the Convy-S to any hopper or bin.

MODBUS FOR CONNECTING

Suitable for connecting the Convy-S to any Supervision system.

TECHNICAL DATA

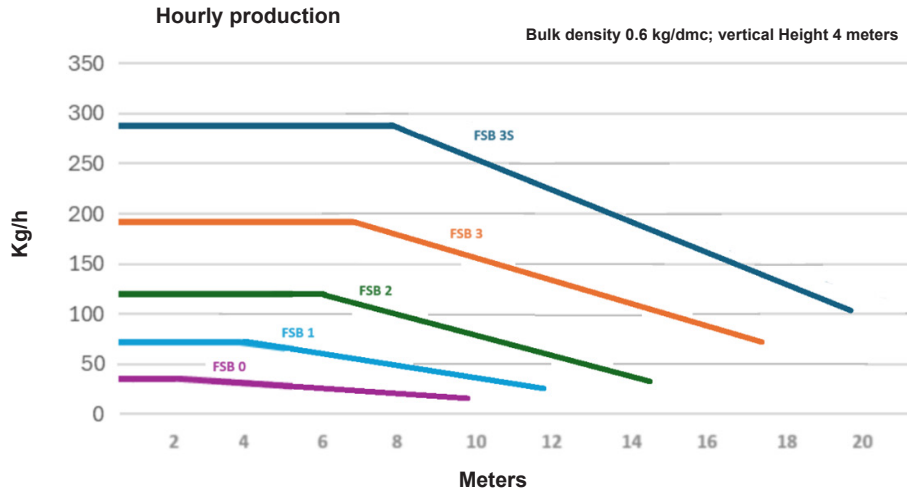

PICTURE INCLUDES OPTIONAL EQUIPMENT TOO (IN DARKER GREY)

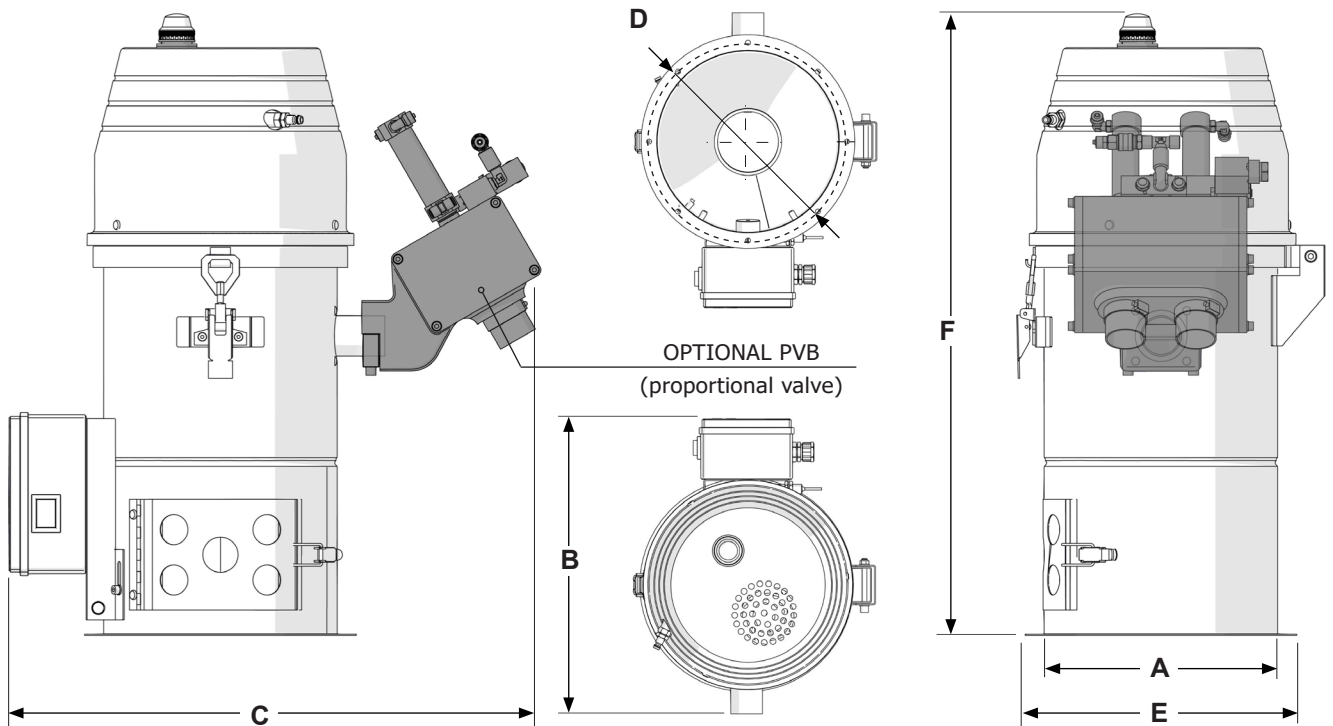

Model	FSB 0	FSB 1	FSB 2	FSB 3	FSB 35
Power supply	230 V / 1Ph. 50-60 Hz				
Blower motor	0.95 kW				
Static negative pressure	22 kPa				
Loader capacity	1.5 L	3 L	5 L	8 L	12 L
Diameter of connection	30 mm	40 mm			
Diameter A of receiver	165 mm	230 mm			
Dimension B	275 mm	355 mm	370 mm	375 mm	
Dimension C (including optional PVB)	445 mm	525 mm	540 mm	545 mm	
Dimension D interaxis of fixing point	180 mm	250 mm			
Dimension E connecting flange	195 mm	270 mm			
Dimension F Height	420 mm	495 mm	530 mm	650 mm	730 mm
Weight (included PVB)	6 kg	9 kg	11 kg	13 kg	15 kg